

### MATERIALS LIST

No.	DESCRIPTION	SPECIFICATION
1.	BODY	CF8M
2.	END CAP	CF8M
3.	BALL	SS316
4.	BOLT WASHER	SS304
5.	BOLT NUT	SS304
6.	BOLT	SS304
7.	SEAT RING	RTFE
8.	BODY SEAL	PTFE
9.	THRUST WASHER	PTFE
10.	STEM SEAL	PTFE
11.	STEM	SS316
12.	GLAND NUT	SS304
13.	HANDLE WASHER	SS304
14.	HANDLE NUT	SS304
15.	LOCKING PAD	SS304
16.	HANDLE	SS304
17.	HANDLE COVER	PLASTIC

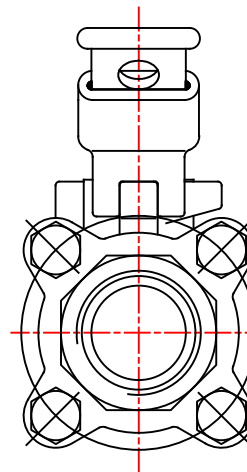
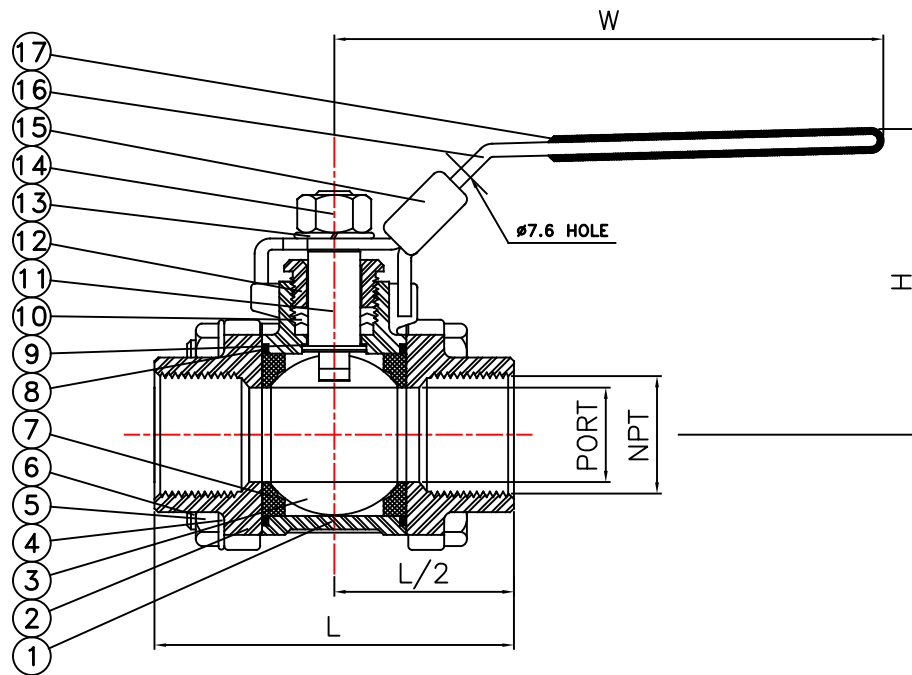

### DIMENSIONS (INCH) (LB) (IN-LB)

SIZE	PORT	L	H	W	A	WEIGHT	TORQUE
1/4"	0.441	2.362	2.165	3.74	0.827	0.93	80
3/8"	0.492	2.362	2.165	3.74	0.827	0.88	80
1/2"	0.63	2.835	2.52	4.921	1.024	1.52	100
3/4"	0.787	3.15	2.638	4.921	1.299	1.96	120
1"	0.984	3.543	3.268	5.512	1.504	2.93	170
1-1/4"	1.26	4.331	3.504	5.512	1.969	4.52	200
1-1/2"	1.496	4.724	3.937	7.874	2.193	6.5	250
2"	2	5.512	4.252	7.874	2.827	10.14	300
2-1/2"	2.559	7.283	5.906	9.843	3.425	21.6	400
3"	3.15	8.071	6.339	9.843	4.173	32.63	650
4"	3.937	9.449	7.087	11.417	5.098	51.81	850

\* LENGTH ACCORDING TO DIN3202-M3

TOLERANCE						DRAWING NO.	
0.5~6	6~30	30~120	120~315	315~1000	1000~	DESCRIPTION	
±0.1	±0.2	±0.3	±0.5	±0.8	±1.2	BV-003T	
APPROVED BY			DRAWN BY		MATERIAL		
			SAMMI				
			3,16,'20		SCALE:FREE		
						JFW INDUSTRIES INC	

REVISE	DATE	APPROVED	REVISE	DATE	APPROVED