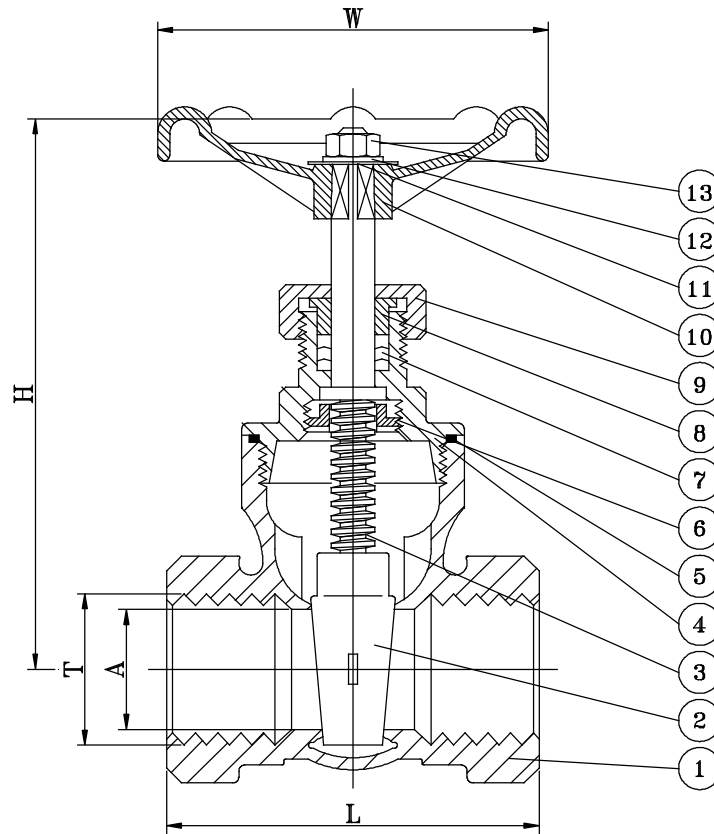

Fig No: GT-200



- Screwed-In Bonnet 1/2"~2"(DN15~DN50)
- Non-Rising Stem
- Solid Wedge Disc
- Body:ASTM A-351 Gr.CF8M(DIN 1.4408) or CF3M
- Disc:ASTM A-351 Gr.CF8M(DIN 1.4408)
- Seat:SS316
- Packing:PTFE.
- Working Pressure:200psi
- End Connections:Threaded
- Threaden Type:ANSI B1.20.1(NPT)
DIN 259/DIN 2999
ISO 228
BSP
PT

MATERIAL LIST

NO	PART NAME	MATERIAL	Q.TY
1	BODY	ASTM A-351 GR. CF8M	1
2	DISC	ASTM A-351 GR. CF8M	1
3	STEM	SS316	1
4	BONNET	ASTM A-351 GR. CF8M	1
5	GASKET PACKING	TEFLON	1
6	STOP RING	SS304	1
7	STEM PACKING	TEFLON	1SET
8	GLAND	SS304	1
9	GLAND NUT	SS316	1
10	HANDLEWHEEL	MICO STEEL	1
11	NAME PLATE	ALUMINUM	1
12	HANDLEWHEEL WASHER	SS304	1
13	HANDLEWHEEL NUT	SS304	1

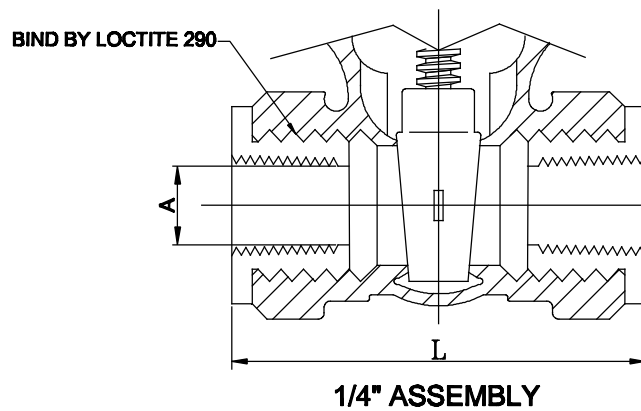

DIMENSION

inch

SIZE	A	H	L	W	T
1/4"	0.43	3.94	2.48	2.48	1/4"NPT,PT
3/8"	0.47	3.94	2.24	2.44	3/8"NPT,PT
1/2"	0.59	3.62	2.17	2.48	1/2"NPT,PT
3/4"	0.79	3.82	2.40	2.76	3/4"NPT,PT
1"	0.98	4.27	2.60	3.15	1"NPT,PT
1-1/4"	1.26	4.86	3.00	3.15	1-1/4"NPT,PT
1-1/2"	1.57	5.75	3.39	3.54	1-1/2"NPT,PT
2"	1.97	6.38	3.74	3.94	2"NPT,PT
2-1/2"	2.56	10.24	4.57	4.72	2-1/2"NPT,PT
3"	3.15	11.61	5.16	4.72	3"NPT,PT

		APPROVED BY.	CHECK BY.	DRAWN BY.	DRAWING NO.		MATERIAL	UNIT	DESCRIPTION
J.F.W. INDUSTRIES, INC.	SING			SAMMI	GT-200			INCH	200 PSI STAINLESS STEEL GATE VALVES SCREWED ENDS
	DATE			06/16/2000	REVISION	01	SCALE	FREE	