

REVISE	DATE	APPROVED	REVISE	DATE	APPROVED

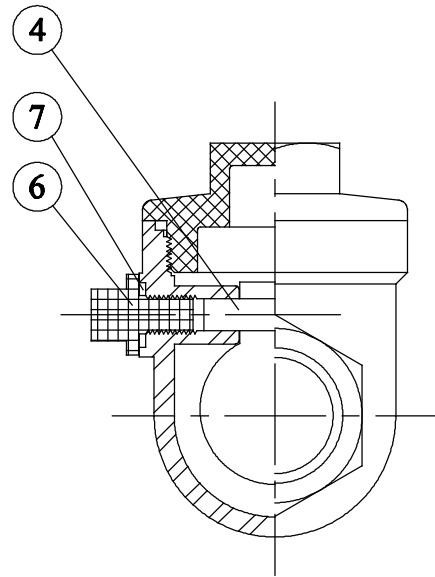
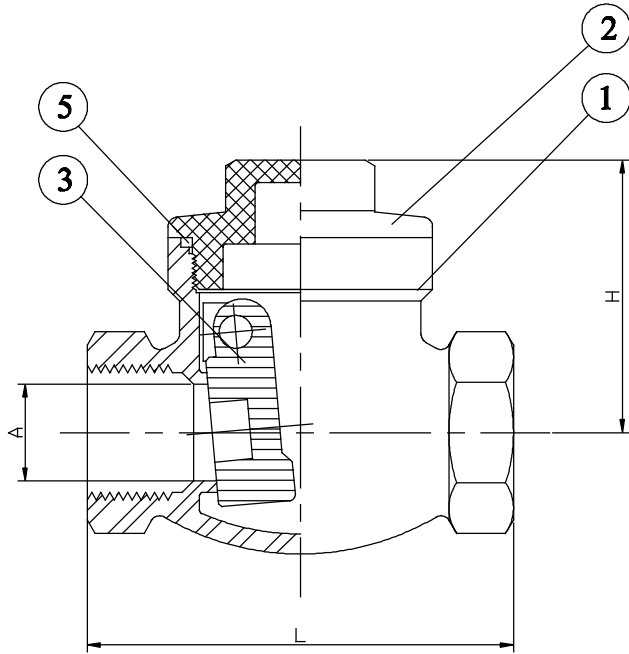

SIZE	1/4"	3/8"	1/2"	3/4"	1"	1-1/4"	1-1/2"	2"	2-1/2"	3"
A	0.43	0.59	0.59	0.79	0.98	1.26	1.57	1.97	2.56	3.15
H	1.65	1.65	1.65	2.01	2.36	2.64	2.95	3.19	3.66	4.09
L	2.56	2.56	2.56	3.15	3.54	4.13	4.72	5.51	7.09	7.87

NO.	DESCRIPTION	MATERIAL	Q'TY
1	BODY	CF8M	1
2	COVER	CF8M	1
3	DISC	CF8M	1
4	HANGER PIN	SUS316	1
5	GASKET	TEFLON	1
6	PLUG	SUS316	1
7	PLUG GASKET	TEFLON	1

TOLERANCE						FIG NO.	SC-200
0.02~0.24	0.24~1.18	1.18~4.72	4.72~12.4	12.4~39.37	39.37~	DESCRIPTION	
±0.004	±0.008	±0.01	±0.02	±0.03	±0.05	SWING CHECK ASSEMBLY (200PSI & PN16)	
APPROVED BY		DRAWN BY		MATERIAL		J.F.W. INDUSTRIES, INC.	
		TED					
		6,5,'01		SCALE:FREE			