

MATERIALS LIST

NO	PART NAME	SPECIFICATION	Q'TY
1	BODY	CF8M	1
2	END CAP	CF8M	1
3	BALL	SS316	1
4	SEAT	PTFE	2
5	STEM	SS316	1
6	THRUST WASHER	PTFE	1
7	STEM PACKING	PTFE	1 SET
8	GASKET	PTFE	1
9	GLAND NUT	SS304	1
10	HANDLE	SS304	1
11	FLOW INDICATOR	SS304	1
12	HANDLE WASHER	SS304	1
13	HANDLE NUT	SS304	1
14	LOCKING DEVICE	SS304	1
15	HANDLE COVER	PLASTIC	1

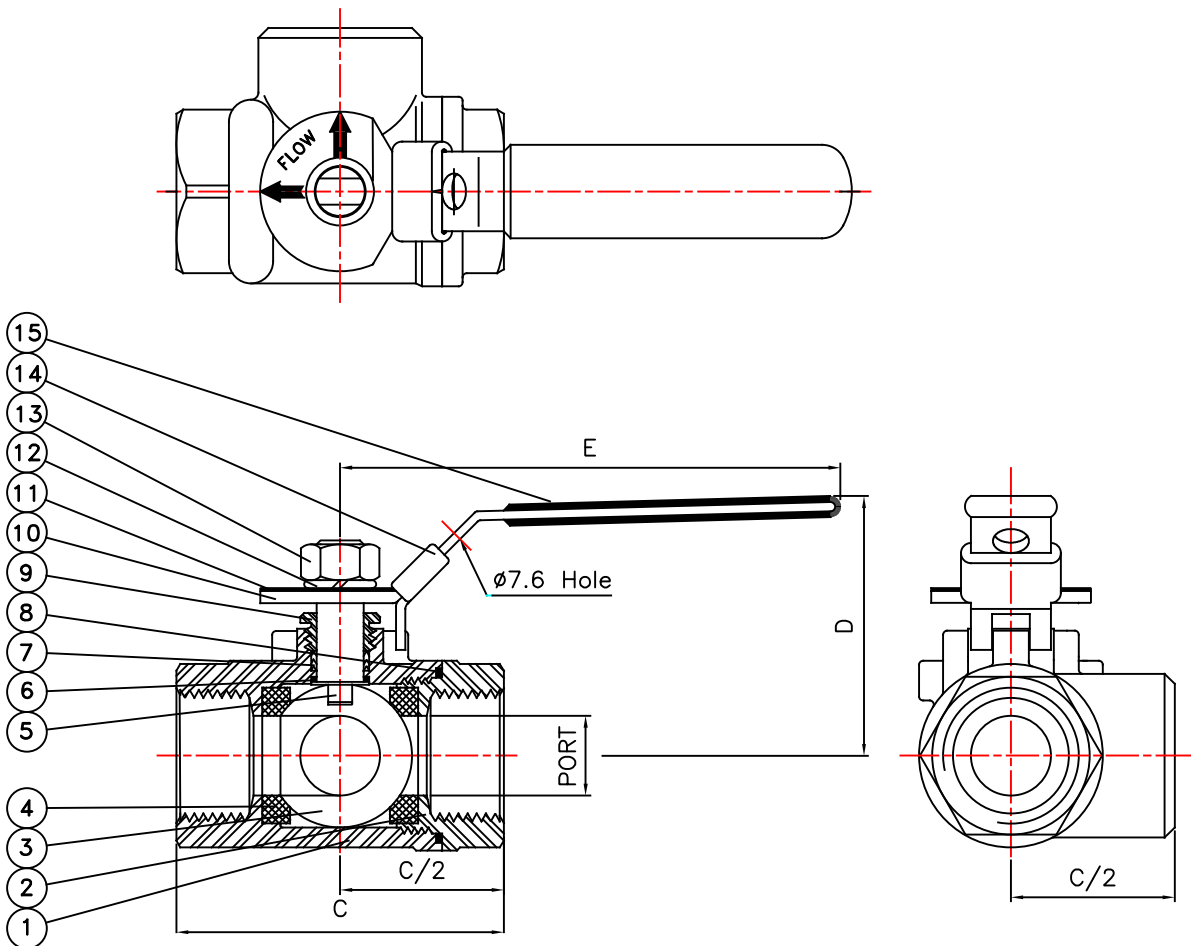

DIMENSIONS (INCH)

SIZE	PORT	C	D	E	LB WEIGHT	IN-LB TORQUE
1/4"	0.504	2.362	2.205	3.74	0.97	40
3/8"	0.504	2.362	2.205	3.74	0.95	40
1/2"	0.504	2.362	2.205	3.74	0.84	40
3/4"	0.63	2.992	2.52	4.921	1.65	70
1"	0.787	3.228	2.598	4.921	2.05	120
1-1/4"	0.984	3.819	2.756	5.709	2.65	140
1-1/2"	1.26	4.488	3.268	5.709	5	160
2"	1.496	5.591	3.465	8.071	7.43	280

TOLERANCE						DRAWING NO.
0.5~6	6~30	30~120	120~315	315~1000	1000~	DESCRIPTION
±0.1	±0.2	±0.3	±0.5	±0.8	±1.2	BV-002-3LP
APPROVED BY	DATE	APPROVED	DATE	APPROVED	DATE	JFW INDUSTRIES INC
						SCALE:FREE

REVISE	DATE	APPROVED	REVISE	DATE	APPROVED