

MATERIALS LIST

No.	DESCRIPTION	SPECIFICATION
1.	BODY	ASTM A-351 GRADE CF8M
2.	END CAP	ASTM A-351 GRADE CF8M
3.	BALL	SS316
4.	SEAT RING	CTFE (25% carbon fiber filled teflon)
5.	BODY SEAL	PTFE
6.	THRUST WASHER	PTFE
7.	STEM SEAL	PTFE
8.	STEM	SS316
9.	GLAND NUT	SS304
10.	HANDLE WASHER	SS304
11.	HANDLE NUT	SS304
12.	LOCKING PAD	SS304 (OPTION)
13.	HANDLE	SS304
14.	HANDLE COVER	PLASTIC

DIMENSIONS (INCH)

SIZE	PORT	L	H	W	D	P
1/8"	0.31	2.17	2.52	3.74	0.63	1/8" PF or NPT
1/4"	0.44	2.17	2.52	3.74	0.63	1/4" PF or NPT
3/8"	0.49	2.17	2.52	3.74	0.63	3/8" PF or NPT
1/2"	0.63	2.56	2.52	4.92	0.75	1/2" PF or NPT
3/4"	0.79	3.03	2.64	4.92	0.87	3/4" PF or NPT
1"	0.98	3.46	3.27	5.51	1.10	1" PF or NPT
1-1/4"	1.26	4.02	3.50	5.51	1.30	1-1/4" PF or NPT
1-1/2"	1.50	4.33	3.94	7.87	1.52	1-1/2" PF or NPT
2"	2.00	4.96	4.25	7.87	2.44	2" PF or NPT

MOUNTING PAD (OPTION)

SIZE	M1	M2	M
1/8" TO 1/2"	0.50	1.12	10-24 UNC
3/4" TO 1"	0.88	1.38	10-24 UNC
1-1/4" TO 2"	1.00	1.50	1/4"-20 UNC

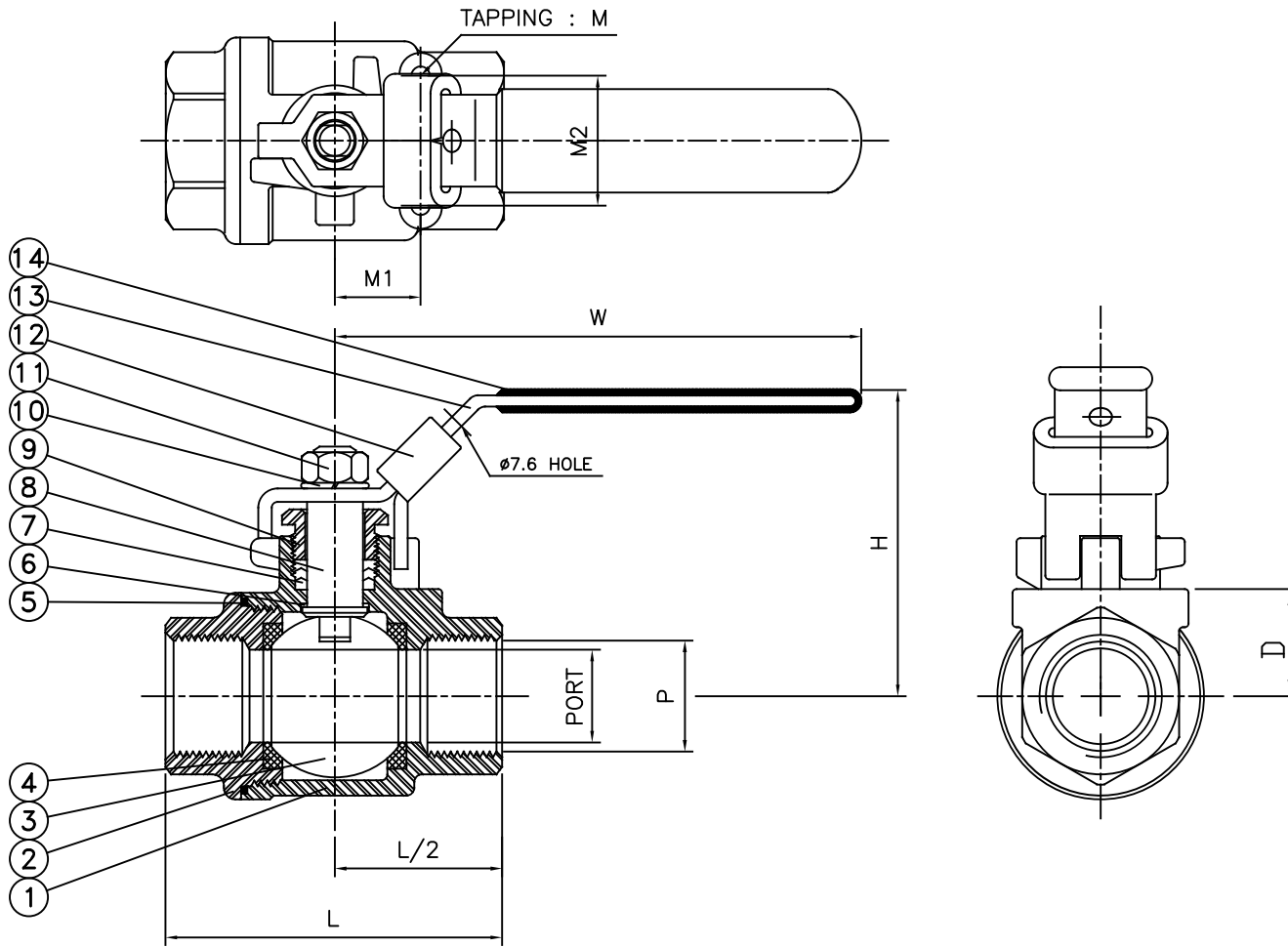

JFW Industries Inc

DRAWN BY	Sammi	SCALE	FREE	PART No.
APPROVED BY		DATE	Dec.21,2016	MATERIAL

REVISION	DESCRIPTION	DATE	APPROVED BY
UNIT	VL-601 THREADED		
TREATMENT	2PC FULL BORE BALL VALVE		
	2000 WOG(1/8"~1"),1500 WOG(1-1/4"~2")		
			DRAWING No./PARTS No.
			VL-601-FS